

---

Explanatory note to the SEE CCR TSOs' proposal for a  
common balancing capacity calculation in accordance  
with Article 37 of Commission Regulation (EU)  
2017/2195 of 23 November 2017  
establishing a guideline on electricity balancing within  
SEE CCR

---

**November 2022**

**Disclaimer:** This explanatory document is submitted by the TSOs of the SEE CCR region for information and clarification purposes only accompanying the TSOs' proposal for a common balancing capacity calculation methodology in accordance with Article 37 of the Regulation 2017/2195 of 23 November 2017 establishing a Guideline on Electricity Balancing.

# 1. Introduction

This technical document sets out the main principles for the coordinated capacity calculation methodology for the balancing timeframe applied in SEE CCR region. It contains a description of both the methodology and the calculation process in compliance with Electricity Balancing Guideline (EB GL).

## 1.1 Overview of BTCC Business Process

The BTCC process is composed of several sub-processes as shown on the process schema below. Each sub-process is linked with all the other sub-processes that depend on it. The BTCC, ID IGM Merging and ID CROSA lanes are activities performed by the RSCs.

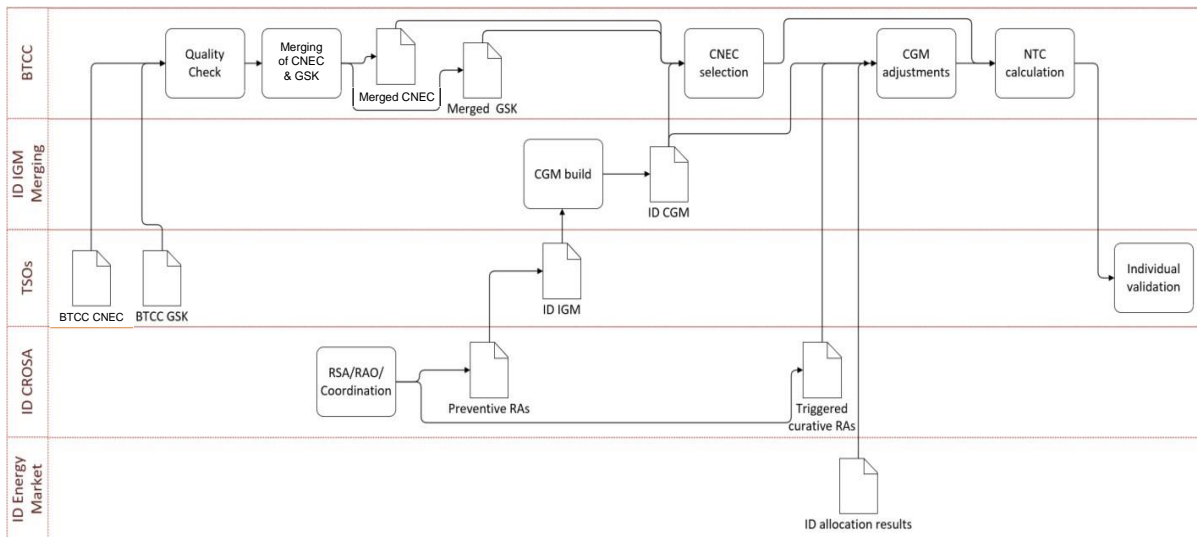

**Figure 1 BTCC HLBP**

A brief description of the sub-processes that comprise BTCC process is provided in Table 1. For the sake of understanding, a short description of processes on which BTCC depends is provided. The full description of the BTCC process and its sub-processes is described in detail in the following chapters.

Sub-process	Description	Inputs	Outputs
Quality Check	The inputs are checked against the quality rules.	-BTCC CNEC -BTCC GSK	-Validated CNEC -Validated GSK
Merging of CNEC and GSK files	The individual CNEC and GSK files of BG, GR, RO are merged.	-Validated CNEC -Validated GSK	-Merged CNEC -Merged GSK
RSA/RAO/Coordination	Security assessment is performed on CCR level. In case of congestions, RAO is performed, and the resulting RAs are coordinated and validated by the involved TSOs.		Among others: -Preventive RAs -Triggered curative RAs
CGM build	The ID IGMs are merged into ID CGM	-ID IGMs	-ID CGMs
CNEC selection	Filtering of CNECs to be considered in the CC.	-Merged CNEC and GSK files -ID CGM -Triggered curative RAs	-Final CNEC list
CGM adjustments	The triggered curative RAs are processed to be considered in the BT CC. The NPs of all BZs are set based on ID allocation results after ID CZGCT.	-ID CGM -Triggered curative RAs -ID allocation results	-Adjusted BTCC CGM
NTC calculation		-BTCC ready CGM -CNECs -TRM	-BT NTC -Final BTCC CGM
Individual validation		-BT NTC -Ex post BT CC CGM	-Final BT NTC

**Table 1 Overview of sub-processes**

## **2. Capacity calculation input**

### **2.1 Transmission Reliability Margin (TRM)**

For the CC performed in BT, the TSOs of the SEE CCR shall define the reliability margin as it is in the ID CC as was calculated at the relevant DA and ID CCM.

### **2.2 Operational security limits and contingencies**

Operational security limits and contingencies in capacity calculation on SEE CCR are provided daily by all TSOs of the SEE CCR region in form of the contingency list and list of critical network elements.

**The Contingency** list describes the contingencies to be assessed during capacity calculation. A contingency can be a trip of a line, a cable or a transformer or a set of the aforementioned contingencies.

**Critical network element (CNE)** is a network element either within a bidding zone or between bidding zones taken into account in the capacity calculation process, limiting the amount of power that can be exchanged. Each participating TSO is required to provide a list of critical network elements (CNEs) of its own control area based on operational experience along with its operational security limits. A critical network element can be an interconnector, an internal line or a transformer. The operational security limits used in the common capacity calculation are the same as those used in operational security analysis. CNEs are independently associated with relevant contingencies.

To this end, as a preparatory step to the CC, the participating TSOs create the list of CNEs to be considered in the CC. This process is called CNEC Selection. CNE(C)s with sensitivities below a specific threshold are filtered out.

During the operational phase of BTCC, the TSOs will have the possibility to reassess the sensitivity threshold if deemed necessary.

TSOs have the possibility to add or remove specific CNECs from the CNEC list. The sensitivity formula is the same that is used in the DA-ID process.

The list of CNECs after the removal of elements that the SEE TSOs do not consider necessary will be considered in the BT CC and is called final CNEC list hereafter.

### **2.3 Generation and Load Shift Keys (GLSK)**

1. Each SEE TSO shall define for its bidding zone and for each MTU a GSK, which translates a change in a bidding zone net position into a specific change of injection or withdrawal in the CGM. This expectation shall be based on the observed historical response of generation units to changes in net positions, clearing prices and other fundamental factors, and thereby contributing to minimizing the RM.
2. In accordance with Article 24 of the CACM Regulation, SEE TSOs developed the following methodology to determine the common generation shift key:

- a. SEE TSOs shall take into account the available information on generation available in the common grid model for each scenario developed in accordance with Article 18 of the CACM Regulation in order to select the nodes that will contribute to the GSK;
  - b. SEE TSOs shall aim to apply a GSK that resembles the dispatch and the corresponding flow pattern, thereby contributing to minimizing the reliability margins;
  - c. SEE TSOs shall define a constant generation shift key per market time unit.
3. For the application of the methodology, SEE TSOs shall define, for the capacity calculation process, GSKs impacted by the actual generation present in the relevant CGM, for each MTU. SEE TSOs shall take into account the available information on generation available in the CGM in order to select the nodes that will contribute to the GSK.
4. SEE TSOs have harmonized their GSK determination methodologies:
  - a. In its GSK, each TSO shall use flexible and controllable production units which are available inside the TSO grid;
  - b. Units unavailable due to outage or maintenance are not included;
  - c. GSK is reviewed on a daily basis or whenever there are changes in the expectations referred to in paragraph (1).
5. For the Greek bidding zone a proportional representation of the generation variation to the remaining capacity, based on ADMIE's best estimate of the initial generation profile, ensure the best modeling of the Greek system.
6. For the Bulgarian bidding zone a proportional representation of the generation variation to the remaining capacity respecting the limits of the generating units, based on ESO EAD's best estimate of the initial generation profile, ensure the best modeling of the Bulgarian system. The nuclear units are not included in the list.
7. The Transelectrica GSK file contains dispatchable units which are available in the day of operation. The nuclear units are not included in the list. The fixed participation factors of GSK are impacted by the actual generation present in the relevant CGM.
8. The GSKs shall be provided to the CCC to be used in the capacity calculation for each bidding zone and also the MTUs for which the GSKs shall be valid. The SEE TSOs shall make ex-post analysis of GSK regularly and if considered necessary request to change it.
9. SEE TSOs shall review and update the application of the generation shift keys methodology, on a yearly basis.

## 2.4 Remedial Actions

Remedial action refers to any measure applied in due time by a TSO in order to fulfil the n-1 security principle of the transmission power system regarding power flows and voltage constraints. Capacity calculation in SEE CCR region considers two types of remedial action:

- Preventive Remedial Actions (PRAs) are those launched to anticipate a need that may occur, due to the lack of certainty to cope efficiently and in due time with the resulting constraints once they have occurred;
- Curative Remedial Actions (CRAs) are those needed to cope with and to relieve rapidly constraints with an implementation delay of time for full effectiveness compatible with the Temporary Admissible Transmission Loading. They are implemented after the occurrence of the contingencies.

The BT CC process is carried out close to Real Time. Therefore, only RAs with very short activation time would be suitable for BTCC and consequently a limited number of RAs could be considered in BTCC. Moreover, the process of optimization, coordination and validation of RAs is time consuming and does not fit in the BT CC time window as defined in SEE CCR. Therefore, BT CC process shall rely on the RAs coordinated and validated in the DA/ID CROSA which precedes BT CC and no RAO will be carried out within the BT CC process. In this way BTCC benefits from preceding processes with sufficient time to perform elaborate calculations and achieves a reliable calculation in the tight BT time window. In particular, the RAs to be considered in the BTCC are:

- all preventive remedial actions as determined, coordinated and validated during day-ahead and intraday Coordinated Regional Operational Security Assessment (CROSA) process. The preventive RAs are included in the CGM that shall be used in the BTCC and therefore no actions are required for their consideration.
- all triggered curative remedial actions as determined, coordinated and validated during day-ahead and intraday Coordinated Regional Operational Security Assessment (CROSA) process. These RAs shall be provided by ID CROSA of SEE CCR and potentially of other CCR whose RAs might have an impact in BTCC.

## 2.5 Common Grid Model

The ID Common grid model (CGM) is used for capacity calculation. The detailed structure of the model, as well as the content is described in the Common Grid Model Methodology (CGMM), which is common for entire ENTSO-E area.

## 2.6 Input data provision deadline

The SEE Balancing Timeframe Capacity Calculation methodology Proposal requires the introduction of two TTC calculation processes:

- a. the BT CCC process 1 starts on D-1 and ends on D.
- b. the BT CCC process 2 is executed entirely in day D.

The aim of these processes is to increase the TTC computation frequency, in such a way that TTC values for MTUs having the higher lead time between the end of the last Intraday Capacity Calculation Process relevant for these MTUs and the start of the given MTU are updated by additional Capacity Calculation Processes based on updated input data (see the Figure below).

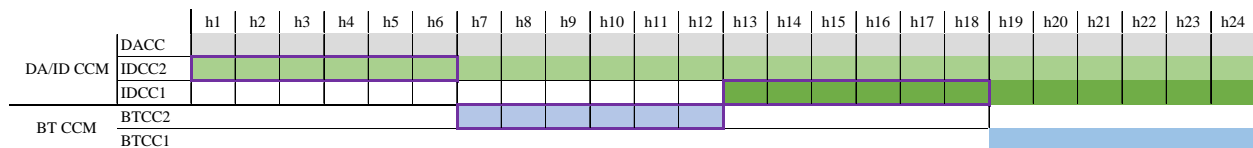

In addition, a TTC update process is foreseen: after each Intraday Gate Closure, TSOs shall monitor any relevant deviation occurred on the assumptions adopted in the latest Capacity Calculation Process affecting this MTU, and possibly the following MTUs, and a new TTC calculation process is triggered in case those deviations are deemed to significantly impact the use of the capacity in the upcoming balancing processes

The proposed structure allows to:

- Maximize the coherency with the “DA/ID CCM” in terms of input data, TTC calculation procedures and expected results.
- Avoid any strong simplification necessary to cope with shorter timelines for the TTC calculation process.
- Ensure updated TTC values: a higher frequency in the occurrence of the TTC calculation process is not expected to improve the quality of the results, considering that significant simplifications would have been required to cope with stricter timelines.
- Update TTC values after any IDGT in case relevant changes occurred in the power system.

The TTC calculation procedure and the input data creation processes are aligned with the ones defined (and implemented) for the Day and Intraday Capacity Calculation processes.

Each TSO shall provide the relevant input data to the Coordinated Capacity Calculator:

- By 23:00 of D-1 for the BT CCC process 1;
- By 11:00 of D for the BT CCC process 2;
- 3 hours before the start of the impacted MTU in case a TTC update process is activated according to Article 11 of the BT CCC methodology.

## 2. Capacity Calculation Approach

Article 37(3) of EBGL requires the EB CCM to be consistent with ID CCM. Therefore, the BTCC is an NTC based CC approach that is adjusted to fit in the tight time window of the BT.

### 3.1 General principles

The Total Transfer Capacity (TTC) for the whole North Greek borders and South Romania borders is assessed using the following principles:

- based on merged ID common grid models;
- the modification of exchanges is realized according to GSKs and Splitting Factor per border
- the maximum current for the network security of Critical Network Elements is respected (taking into account effects of remedial actions used);

### 3.2 Preparatory sub-processes

The preparatory sub-processes are illustrated in Figure 1 and will be described in chronological order. The CNEC and GSK files of the participating TSOs are merged into a single CNEC and a single GSK file. The ID CGM along with the list of triggered CRAs from ID CROSA are available for the BTCC process. The CNEC selection sub process is performed based on the aforementioned inputs. The final CNEC list is created.

The BTCC shall be performed having as starting point the allocation results after ID CZGCT. To this end, the ID CGM is updated in order to reflect the allocation results as soon as they are available.

### 3.3 NTC calculation

- (1) The CNTC computation is a centralized calculation based on AC load flow which delivers the main parameter needed for the definition of CNTC domain: TTC. The TTC represent the maximum power exchange on a bidding zone border and calculation shall according to the following procedure:
  - (a) use the common grid model, generation shift keys, and list of CNECs defined in accordance with the BT CCC methodology to calculate maximum power exchange on bidding zone borders, which shall equal the maximum calculated exchange between two bidding zones on either side of the bidding zone border respecting operational security limits;
  - (b) adjust maximum power exchange using remedial actions.
- (2) The CCC shall define the values of TTC for each MTU for the north Greek borders and south Romanian borders.
- (3) The NTC values for the north Greek borders and south Romanian borders are determined with the following equations:

$$NTC_{NORTH-GREEK-BORDERS} = TTC_{NORTH-GREEK-BORDERS} - RM_{NORTH-GREEK-BORDERS}$$

$$NTC_{SOUTH-ROMANIAN-BORDERS} = TTC_{SOUTH-ROMANIAN-BORDERS} - RM_{SOUTH-ROMANIAN-BORDERS}$$

- (4) The splitting factor used for balancing capacity calculation will be the same that is used in the relevant DA-ID processes.
- (5) The CCC (RSC) shall provide to TSOs the NTC values per border for validation.

### 3.4 Results



The set of results is:

- The initial (merged) grid model and the final (merged) grid model corresponding to the final state of the network for a maximum secured northern Greek and South Romania power exchange in both directions;
- Final list of GSKs, CNEC files, and Remedial Actions;
- $TTC_{total}$ ;  $NTC_{total}$ ;  $NTC_{per\ border}$ ;
- Limiting elements of  $TTC_{total}$  (Critical Network Elements and Critical Outages);

### 3.4 Fall back procedure

At the beginning and during every BT CC process the availability of all necessary files is constantly checked. For files that are missing or do not respect the formatting rules, automatic replacement is performed. If a necessary file is not received in time and no replacement is possible or the calculation dose not succeed, the process is ended and reported as failed. In case of process failure, TSOs shall use the cross-zonal capacity remaining after the ID cross-zonal gate closure time.

## 4. Timescale for implementation

A post-go live study phase, which would focus on possible benefits of getting a process with higher frequency and closer to real-time input updates.

The next figure highlights the dependencies of BTCC process with ROSC. It is especially relevant to highlight that BTCC first step implementation should take place after the implementation of ROSC version 2 go-live (implementation of 3 ID CROSAs):

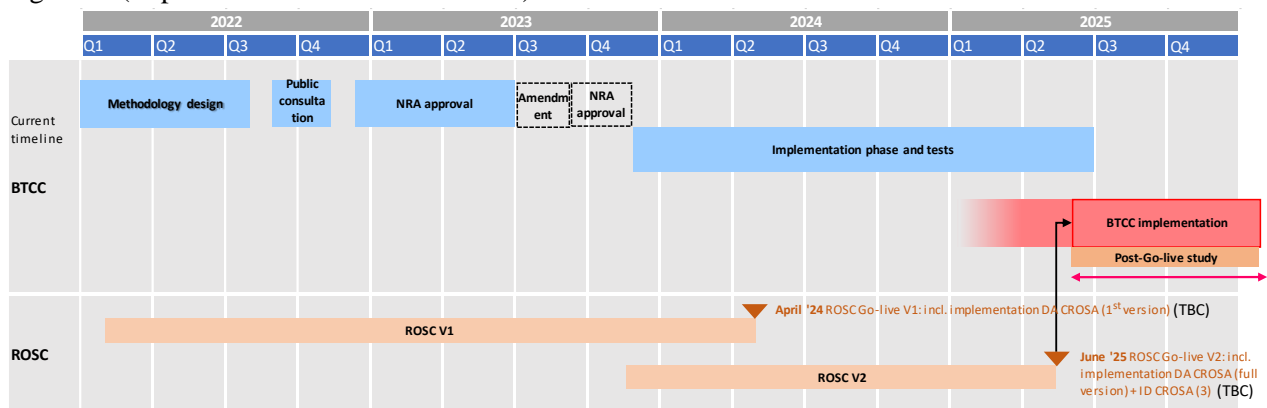

Figure 2 Implementation timeline