

# Explanatory Note of the Coordinated NTC methodology for GRIT CCR

Consultation document

<b>Version</b>	1.0
<b>Date</b>	03-08-2017
<b>Status</b>	<input type="checkbox"/> Draft <input checked="" type="checkbox"/> Final

## Contents

1.	Introduction.....	3
2.	Coordinated NTC calculation methodology .....	3
2.1.	Inputs.....	3
2.1.1.	Critical network elements and contingencies .....	3
2.1.2.	Operational security limits.....	4
2.1.3.	Reliability Margin (RM) .....	4
2.1.4.	Base Case - Individual Grid Model (BC-IGM) .....	5
2.1.5.	Generation Load Shift Key (GLSK).....	7
2.1.6.	Remedial Action (RA) .....	8
2.2.	Capacity calculation approach .....	9
3.	Coordinated NTC calculation process .....	9
3.1.	Creation of a common grid model (CGM) .....	9
3.1.1.	Individual Grid Model (IGM) .....	9
3.1.2.	IGM replacement for CGM creation .....	10
3.1.3.	Common Grid models.....	10
3.2.	Quality check .....	10
3.3.	Regional calculation of cross-zonal capacity .....	11
3.3.1.	The capacity calculation process .....	11
3.3.2.	The TTC calculation.....	12
3.3.3.	The voltage validation .....	15
3.3.4.	The final validation .....	16
3.4.	Backup & Fallback processes.....	16
3.4.1.	Backups and replacement process.....	16
3.4.2.	Fallback NTC values .....	16
4.	Transparency.....	17
5.	Timescale for the CCM implementation.....	18
5.1.	Prerequisites.....	18
5.2.	Timeline for implementation of the CCM .....	18

## 1. Introduction

This technical document sets out the main principles for the Coordinated Capacity Calculation (CCC) methodology for the day-ahead (DA) and intraday market (ID) timeframes applied in the Greece-Italy area (GRIT). It contains a description of both the methodology and the calculation process in compliance with the Capacity Allocation and Congestion Management guideline (hereafter CACM).

The participating TSOs for this calculation are Terna (IT) and ADMIE (GR).

The border between Greece and the connecting Italian Bidding Zone and all the borders between internal Italian Bidding Zones are considered.

## 2. Coordinated NTC calculation methodology

### 2.1. Inputs

In order to allow the Coordinated Capacity Calculator to perform the relevant CCC processes, each TSO for the GRIT region shall provide the following relevant input data:

- Critical elements and contingencies;
- Operational security limits;
- Reliability Margins;
- Base Case – Individual Grid Models;

In this chapter details about the previous data are described.

#### 2.1.1. Critical network elements and contingencies

A Critical Network Element (CNE) is a network element either within a bidding zone or between bidding zones monitored during the CCC process. The CNEC (Critical Network Element and Contingencies) is a CNE limiting the amount of power that can be exchanged, potentially associated to a contingency. They are determined by each GRIT TSO for its own network according to agreed rules, described below.

The CNECs are defined by:

- A CNE: a line or a transformer that is significantly impacted by cross-border exchanges;
- An “operational situation”: base case (n regime) or contingency cases (N-1, N-2).

A contingency is defined as the trip of one single or several network elements that cannot be predicted in advance. A scheduled outage is not a contingency. The normal type of contingency comprises the loss of a single element, which can be:

- a line
- a tie-line
- a DC link
- a unit

- distributed generation of a relevant size like a clustered wind farm, cogeneration, etc...
- a transformer (including Phase Shifter Transformer
- a large voltage compensation installations.

Contingencies situation could result from the combined loss of several elements.

### 2.1.2. Operational security limits

#### Maximum permanent and temporary current on a Critical Branch

The maximum permanent admissible current/power means the maximum loading that can be sustained on a transmission line, cable or transformer for an unlimited duration without risk to the equipment.

The temporary current/power limit means the maximum loading that can be sustained for a limited duration without risk to the equipment (e.g. 120% of permanent physical limit can be accepted during 20 minutes).

Each individual TSO is responsible for deciding which values (permanent or temporary limit and duration of each overload) should be used.

As thermal limits and protection settings can vary in function of weather conditions, different values are calculated and set for the different seasons within a year. These values can be also adapted by the concerned TSO if a specific weather condition is forecasted to highly deviate from the seasonal values.

#### Maximum/minimum voltage on a node of the network

If the voltage on a node is significantly impacted by cross-border exchanges, the voltage on this element shall be monitored in the CCC process.

Each TSO shall specify the voltage limits for each element of its transmission system and/or the maximum acceptable deviation between the initial (N-state) and the final (after contingency) values.

### 2.1.3. Reliability Margin (RM)

*Disclaimer: Please be informed that the Reliability Margin calculation methodology is still under development within the GRIT CCR and, currently, reliability margins are not applied in the GRIT Region. A proposal for computing and applying RMs in the GRIT Region will be developed by the concerned TSOs and submitted to the relevant NRAs no later than 12 months after the approval of the CCC methodology.*

The methodology for the CCC is based on forecast models of the transmission system. The inputs are created two days before the delivery day with the best available forecast. Therefore the outcomes are subject to inaccuracies and uncertainties. The aim of the reliability margin is to cover these inaccuracies and uncertainties induced by those forecast errors.

In this moment, the TSOs of GRIT Region do not apply any reliability margin, adopting NTC values equal to the computed TTC values.

NRAs of GRIT region shall decide upon the necessity to applying reliability margin in the CCC process. In case it is decided to have such margin, in line with the CACM requirements, the methodology for computing Reliability Margins will be defined and tested. Since the introduction of a reliability margin can significantly increase the energy prices, this methodology and the related impact assessment will

be submitted to the concerned NRAs for a final decision.

## 2.1.4. Base Case - Individual Grid Model (BC-IGM)

### 2.1.4.1. BC-IGM preparation

Basis for the Individual Grid Model (IGM), adopted in the CCC process, is a past snapshot (SN) of the grid, assumed to be representative of the expected conditions for the market time unit under assessment.

The selected SN will be updated in order to correctly represent the market time unit (obtaining the so called “Base Case – Individual Grid Model”) in terms of:

- Grid topology: outages of grid elements is adapted according to the approved outages plans;
- Load conditions: most recently updated load forecast is implemented;
- Conventional generation sheet:
  - for the D-1 CCC process, the best available forecast is adopted,
  - for the ID CCC process, the last available market results are adopted;
- Renewable generation infeed: the best available forecasts are adopted;
- Net positions and initial cross-border exchanges, accordingly to the approach described in the following paragraph.

The BC-IGM prepared by the GRIT TSOs will then be merged into a Common Grid Model by the Coordinated Capacity Calculator.

### 2.1.4.2. Coordination of the net positions and initial cross-border exchanges

#### Day-Ahead timeframe

Forecasting of the net positions two days preceding the delivery day in GRIT CCR is based on a common process established in ENTSO-E: the Common Grid Model Alignment (CGMA). This centrally operated process ensures the grid balance of the models used for the CCC across Europe. The process is described in the Common Grid Model Alignment Methodology (CGMAM), which was approved by all TSOs in ENTSO-E.

Main concept of the CGMAM is presented in Figure 1 below:

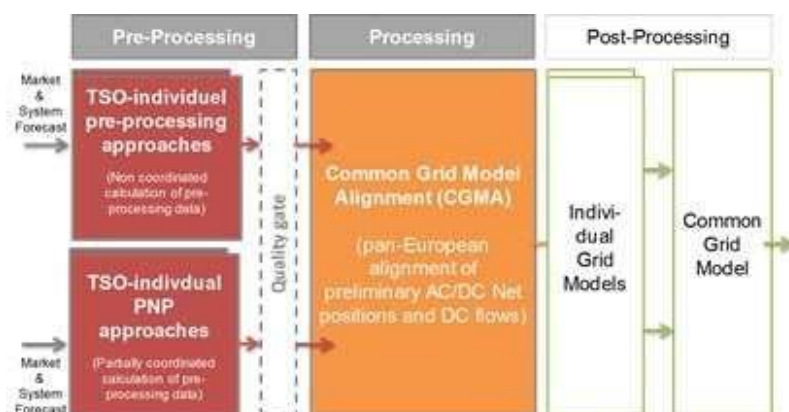

Figure 1: Main concept of the CGMAM

The CGMAM input data are created in the pre-processing phase, which shall be based on the best available forecast of the market behavior and Renewable Energy Source (RES) generation.

Pre-Processing Data (PPD) of CGMA are based on either an individually or regionally coordinated forecast. Basically the coordinated approach shall yield a better indicator about the final net position than an individual forecast. Therefore, TSOs in GRIT CCR agreed to prepare the PPD in a coordinated way.

The main concept of the coordinated approach intends to use statistical data as well as linear relationships between forecasted NP and input variables. The data shall represent the market characteristic and the grid conditions in the given time horizon. The coefficients of the linear model will be tuned by archive data.

The result of the process is the “Balanced Net Position” (BNP) for each control area and for each market time unit.

The above approach is not applied to the GR-IT border since respectively the two bidding zones within the same synchronous area are linked with a single DC line, operated as a DC line (and not operated in AC-simulated mode).

The reason for the DC line exception is that the preliminary DC flows will hardly be modified (if at all). In other words, the balanced flow values for the DC lines would likely be identical to the preliminary flows. This is due to the very large weighting factor that is applied to standard AC connections as well as the lack of a capacity restriction for the latter. The entire adjustment required would effectively be made via the AC connection(s), not the DC line.

For the time being, the CGMA process (effectively) keeps such within-synchronous-area DC lines out of scope; i.e., the preliminary DC flows on such lines will not be modified by the CGMA algorithm. TSOs should therefore use particular care when agreeing on the flows on such DC lines ex ante.

According to above description, TSOs of the GRIT region will accordingly adapt the net position of their control area (as the result of the CGMA process) and coherently define cross-border exchanges on each relevant border. In particular:

- The exchange program on the GR-IT border is agreed among the GRIT Region TSOs and based on the best available forecast, respecting the NTC values computed within the long term timeframes;
- The exchange program on the borders between internal Italian Bidding Zones are defined according to the best available forecast and respecting the NTC values computed within the long term timeframes.

#### Intra-Day timeframe

The net position of each bidding zone of the GRIT region and the cross-border exchanges on each border are defined according to the latest available market results.

### 2.1.5. Generation Load Shift Key (GLSK)

#### 2.1.5.1. GLSK files

GLSKs are needed to transform any change in the balance of one bidding zone into a change of injections in the nodes of that bidding zone. GLSKs are elaborated on the basis of the forecast information about the generating units and loads.

GLSK file is defined for each:

- control area: GLSK is computed for each relevant network node in the same control area;
- and time interval: GLSK is dedicated to individual market time unit in order to model differences between different system conditions.

In order to avoid newly formed unrealistic congestions caused by the process of generation shift, TSOs should be able to define both generation shift key (GSK) and load shift key (LSK):

- Generation shift: GSK constitute a list specifying those generators that shall contribute to the shift.
- Load shift: LSK constitute a list specifying those load that shall contribute to the shift in order to take into account the contribution of generators connected to lower voltage levels (implicitly contained in the load figures of the nodes connected to the 220 and 400 kV grid).

If GSK and LSK are defined, a participation factor is also given:

- G(a) Participation factor for generation nodes
- L(a) Participation factor for load nodes

The sum of G(a) and L(a) for each area has to be to 1 (i.e. 100%).

Hence, for a given control area and a market time unit, a GLSK file contains for each node of the relevant grid:

- Node identification code;
- Available upward margin;
- Available downward margin;
- Merit order rank.

How to distribute the shift among different generators and loads connected to the same node is then defined according to the participation factors.

#### 2.1.5.2. The merit order shift

This kind of shift methodology will be implemented in GRIT Region.

The main reason for this choice is due to the fact that both electrical systems have a high level of RES generation installed. Those generators as well as the conventional generation are geographically located in different areas of the countries, then for different generation profiles we get different power flows in the grid elements and consequently different stress areas in the systems with potential impact in the NTC calculations. Some examples:

- If the wind production is high the marginal production could be reduced;
- If the winter is wet the marginal price of hydro power-plants could be lower than the marginal price of thermal power-plants, and vice-versa for dry seasons;
- Depending on the primary sources' prices, the market behavior will be different and affect the location of the production.

#### 2.1.6. Remedial Action (RA)

During coordinated NTC calculation, GRIT TSOs will take into account Remedial Actions (RAs), that refers to any measure applied in due time by a TSO in order to fulfill the n-1 security principle of the transmission power system regarding power flows and voltage constraints.

The general purpose of the application of RAs is to maintain the transmission system within the operational security limits during the CCC process, where maximum power exchanges are reached. The application of proper RAs in the context of the capacity calculation can allow an increase of NTC values released to the markets, with subsequent benefits for the system.

RAs can be classified in the following two categories:

- Preventive Remedial Actions (PRAs) are those launched to anticipate a need that may occur, due to the lack of certainty to cope efficiently and in due time with the resulting constraints once they have occurred.
- Curative Remedial Actions (CRAs) are those needed to cope with and to relieve rapidly constraints with an implementation delay of time for full effectiveness compatible with the Temporary Admissible Transmission Loading. They are implemented after the occurrence of the contingencies. They shall respect the following requisites:
  - a) If manually implemented in real time, they have to be:
    1. Simple (imply a limited number of maneuvers)
    2. Fast in implementation (according to the security criteria adopted)
    3. 1 to 1 with a contingency i.e. a single set of predefined manual actions can be applied in real time to solve one contingency effects
    4. Consistent with NCCs operational practice (i.e. These actions have to be included in the operating instruction of the NCCs)
  - b) If automatically operated, the operators are not involved in implementation in real time. Therefore the constraints in a) are not applicable.

The possible types of RAs considered in the CCC process are the following:

- Changing the tap position of a phase shifting transformer (PST);
- Topological measure: opening or closing of one or more line(s), cable(s), transformer(s), bus bar coupler(s) or switching of one or more network element(s) from one bus bar to another;
- Change of generator in-feed or load;
- Change the flow in the HVDC links;



- Change the flow in a line using a FACTS (flexible alternating current transmission system);
- Change the voltage on a node by activating/deactivating reactance(s) or capacitor(s).

All explicit RAs applied for NTC calculation must be coordinated in line with article 25 of Regulation (EU) 2015/1222 (CACM). Prior to each calculation process, the TSOs of a bidding zone border shall agree on the list of remedial actions that can be shared between both in the capacity calculation. This means that a shared remedial action of one TSO is used to solve the contingency in the grid of another TSO.

These shared remedial actions can only be activated with prior consent of the neighboring TSO since their activation have a significant impact on its control area.

## 2.2. Capacity calculation approach

Due to the specificities of the GRIT CCR, GRIT TSOs will use coordinated NTC approach to determine the cross-border capacities for each border of the GRIT CCR. This choice is mainly driven by the network structure of the GRIT Region, which is mainly “non-meshed” (the only meshed part is connected by HVDC links).

During the DA and the ID CCC processes, the Total Transfer Capacity (TTC) at each border of GRIT region shall be assessed in both border direction:

- Using Alternate Current (AC) load-flow algorithm in order to assess (n-1) network security of the relevant CNECs, taking also into consideration the beneficial effects of coordinated remedial actions;
- Based on:
  - merged day-ahead CGMs (D2CF merged models) for DA CCC process;
  - merged intraday CGMs (DACF merged models) for ID CCC process;
- Applying modification of cross border-zonal exchanges according to GLSK files. The corresponding method is detailed in the next paragraph.

## 3. Coordinated NTC calculation process

### 3.1. Creation of a common grid model (CGM)

#### 3.1.1. Individual Grid Model (IGM)

All TSOs develop scenarios for each market time unit and establish the IGM. This means that GRIT TSOs will create:

- hourly IGMs for each delivery day (D) in D-2. These models shall be used in the DA CCC process for the creation of the D-2 Common Grid Models;
- hourly IGMs for each delivery day (D) in D-1. These models shall be used in the ID CCC process for the creation of the D-1 Common Grid Models.

These IGMs shall include all the relevant data described in paragraph 2.1.4.

The detailed structure of the model, as well as the content is described in the Common Grid Model Methodology (CGMM), which is common for entire ENTSO-E area.

### 3.1.2. IGM replacement for CGM creation

If a TSO cannot ensure that its D2CF IGM for a given market time unit is available by the deadline, or if the D2CF IGM is rejected due to poor or invalid data quality and cannot be replaced with data of sufficient quality by the deadline, the merging agent will apply all methodological & process steps for IGM replacement as defined in the CGMM (Common Grid Model Methodology).

### 3.1.3. Common Grid models

GRIT TSOs shall provide the GRIT Coordinated Capacity Calculator with an IGM for each market time unit.

The individual TSOs' IGMs are merged to obtain a CGM according to the CGMM. The process of CGM creation is performed by the Coordinated Capacity Calculator and comprises the following services:

- Check the consistency of the IGMs (quality monitoring);
- Merge D-2 IGMs and create a CGM per market time unit;
- Make the resulting CGM available to all TSOs.

The merging process is standardized across Europe as described in European Merging Function (EMF) requirements. As a part of this process the Coordinated Capacity Calculator checks the quality of the data and requests, if necessary, the triggering of backup (substitution) procedures (see below).

Merging process can be performed using common Entso-e tools and methods (if available).

GRIT CGM represents the part of the GRIT transmission system relevant for the CCC process.

## 3.2. Quality check

The Coordinate Capacity Calculator gives a feedback to the TSOs of GRIT Region about the correctness of their input files used for CCC process. This check concerns the following input files:

- IGMs provided by TSO of GRIT Region
- GLSK provided by TSO of GRIT region
- CGM (merged of IGM files)

The quality has to be done for each file provided by TSOs of GRIT region and for the merged CGM file. The optimal solution in an automatized process is where the uploading TSO of GRIT region gets a feedback when files are uploaded to a common system and the quality check starts immediately.

Quality checks can be performed using common Entso-e tools and methods (if available).

### 3.3. Regional calculation of cross-zonal capacity

#### 3.3.1. The capacity calculation process

For each relevant market time unit, the DA and the ID CCC processes designed in the GRIT CCR are respectively represented in figure 2 and in figure 3.

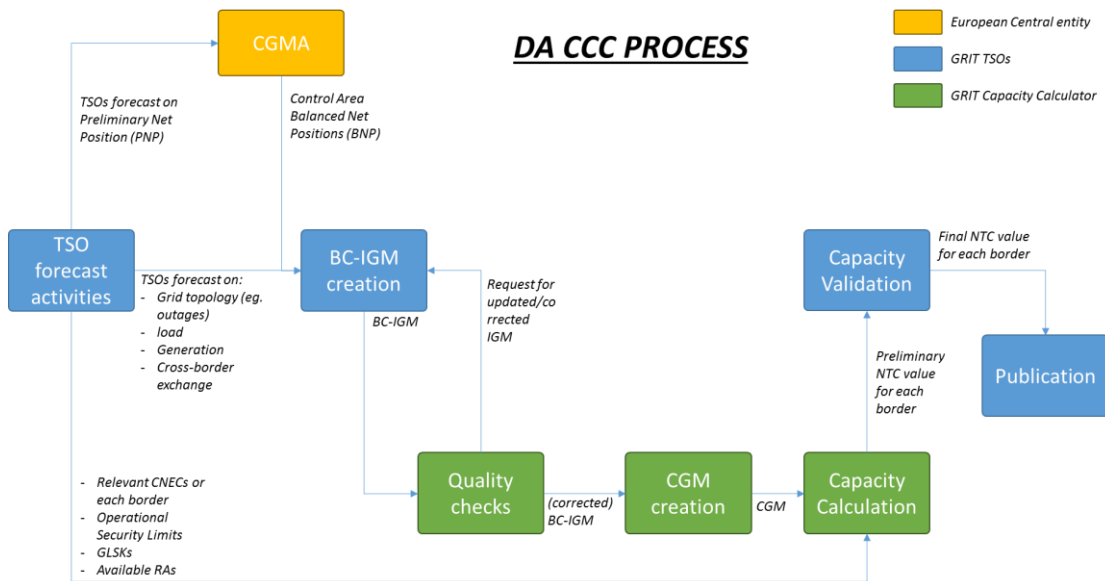

Figure 2: DA CCC process

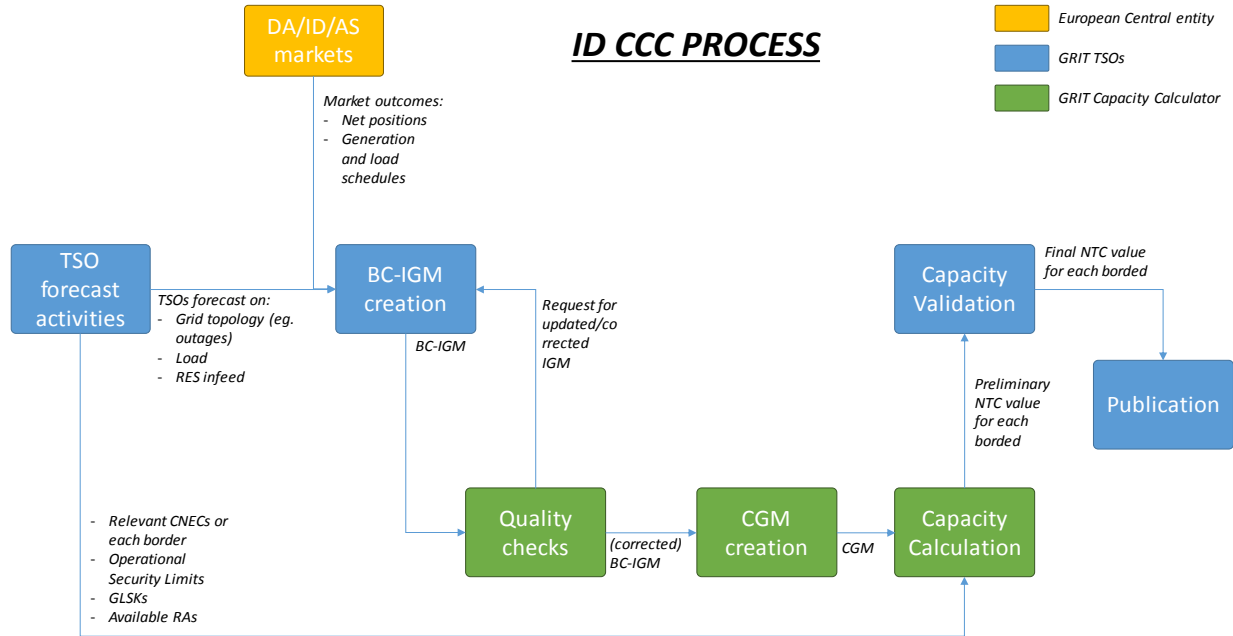

Figure 3: ID CCC process

### 3.3.2. The TTC calculation

The Coordinated Capacity Calculator will determine the Total Transfer Capacity (TTC) available on all the borders which are part of the GRIT Region.

The TTC calculation is based on:

- Alternate Current (AC) load flow algorithm, considering reactive power limit
- Merged CGM file
- Modifications of exchanges has to be realized according the merged GSK file
- Respect of Network security for Critical Network Element with Remedial Action provided

This computation is performed separately for each relevant market time unit and for each border and direction starting from the relevant CGM.

In particular, for computing the TTC from the bidding zone A to the bidding zone B, starting from the relevant CGM, the flow from A to B is stepwise increased or decreased until an unsecure/secure TTC situation is detected.

The TTC calculation sub-process is described in figure 4.

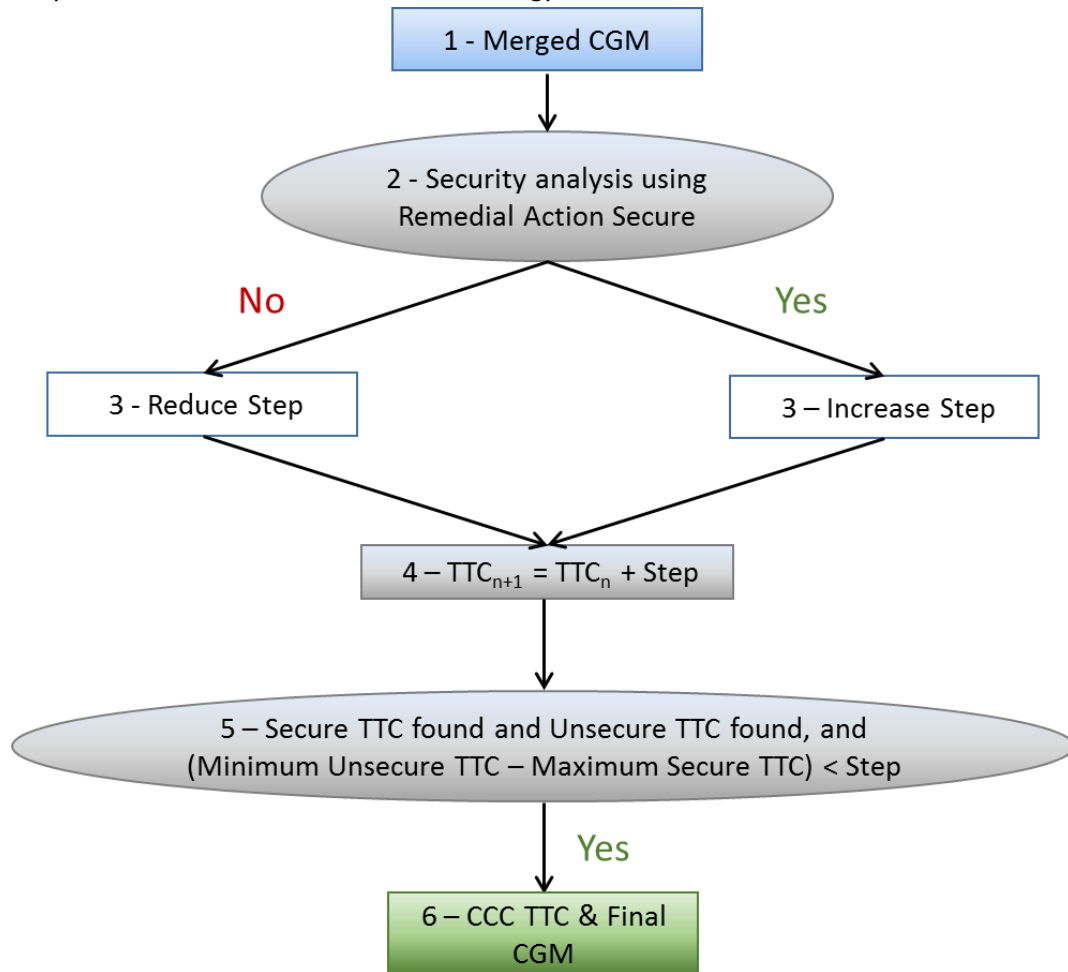

Figure 4: TTC calculation sub-process

1. The network used for TTC calculation at each border of GRIT Region and direction is the merged CGM.
2. This step aims at identifying a **combination of remedial actions which guarantees the respect of security constraints** declared as input in paragraph 2.1.6. Such a combination may not exist, in which case the level of TTC is considered as unsecure, otherwise it is considered as secure.
3. It is up to the Coordinated Capacity Calculator to choose the most suitable method to determine the step of each loop.

Here is an example of Dichotomy approach for the determination of step:

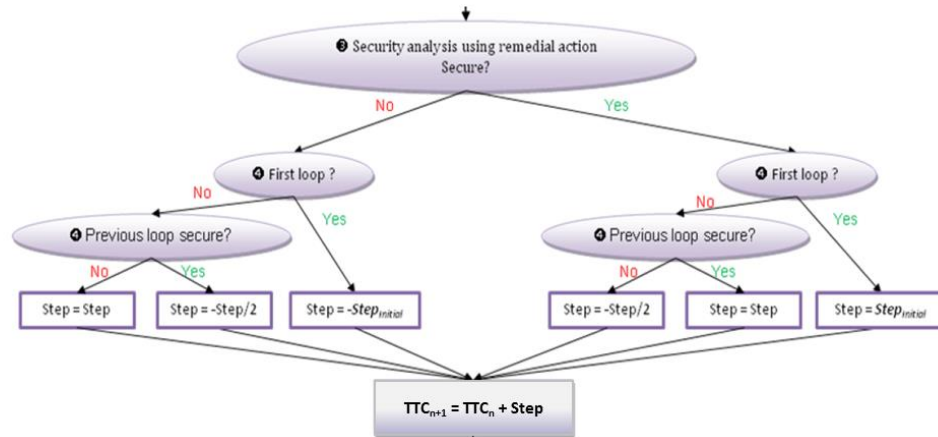

Figure 5: The dichotomy process

For the first loop, step is initialized at  $Step_{Initial}$  if network is secured,  $-Step_{Initial}$  if network is not secured.

As long as the network is secure, Imports are increased by the step.

As long as the network is not secure, Imports are decreased by the step.

When the network becomes secure or not secure, Step is divided by -2.

4. For each step, the CGM is modified in order to reach the target TTC using the GLSK shift method, described in figure 6.
  - a generation upward shift in all the bidding zones with a positive sensitivity on the flow from A to B and
  - a generation downward shift in all the bidding zones with a negative sensitivity on the flow from A to B;

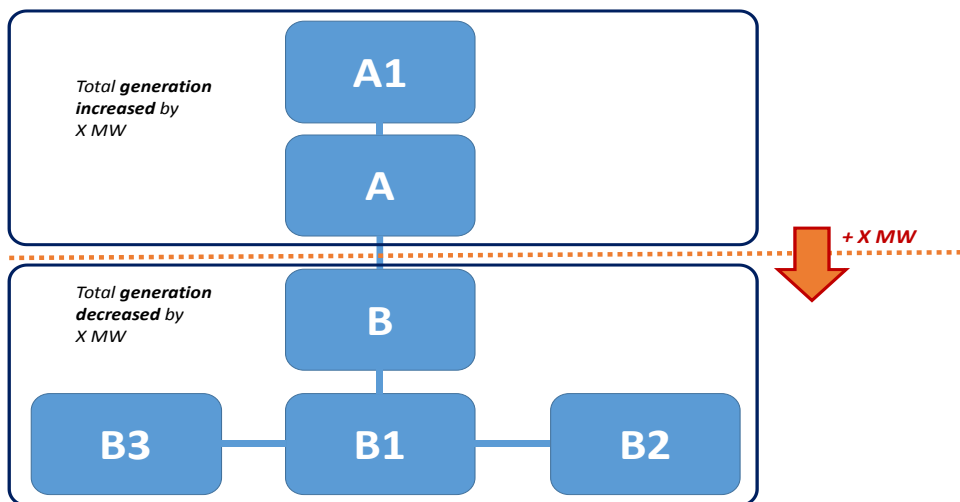

Figure 6: Stepwise flow increase from A to B

5. As a long both a secure (no violation of operational security limit of relevant CNECs) and an unsecure situations have not been found, new iteration is performed.

As soon as at least one secure and one unsecured situations have been found, if the difference between the “*Maximum Secure TTC*” and the “*Minimum Unsecure TTC*” is higher than the Step<sub>Threshold</sub>, a new level of TTC is studied. (This new level of TTC should be between the maximum secure TTC and the minimum Unsecure TTC). The dimension of the Step<sub>Threshold</sub> cannot be bigger than 10% of the maximum TTC value on that border and direction during the previous solar year.

If the difference between the “*maximum secure TTC*” and the “*minimum Unsecure TTC*” is lower or equal than Step<sub>Threshold</sub>, the calculation ends.

6. For the **Maximum TTC for each border and direction of GRIT Region** the security of the network is ensured and remedial actions are used in order to maximize cross-zonal capacity.

### 3.3.3. The voltage validation

#### Temporary implementation:

The coordinated capacity calculator has also to verify that, after a set of contingencies, the voltage level on some selected grid elements is within a safety range based on the TSO operational rules.

1. If yes, the TTC value obtained from the process described in the previous chapter is confirmed.
2. If no, the coordinated capacity calculator can then apply a list of specific remedial actions defined by the TSOs such as topological actions, activation of reactance(s), capacitor(s) and FACTS.
  - a. If non-costly remedial actions other than topological ones relieve the constraint, the TTC value obtained from the process described in the previous chapter is confirmed
  - b. If topological remedial actions are to be applied in order to relieve the constraint:
    - i. A backward stepwise approach is applied without applying any topological RA, in order to identify the maximum cross-border exchange that is compatible with the voltage security ranges in absence of topological RA;
    - ii. In parallel, the initial CGM shall be adapted accordingly and the stepwise process described in the previous chapter shall be performed again;
    - iii. Finally, the maximum value among the two is adopted.
  - c. If the coordinated capacity calculator cannot ensure the transmission system is maintained within the operational security limits with this level of exchange, a backward stepwise approach is applied in order to identify the maximum cross-border exchange that is compatible with the voltage security ranges.

#### Final implementation:

Power flows and voltage levels will be evaluated within the same sequence of the capacity calculation process.

### 3.3.4. The final validation

Once the coordinated capacity calculator has calculated the TTC, it provides the concerned TSOs with these values. Each TSO then has the opportunity to validate the TTC value calculated centrally or can reduce the value in case the centralized calculation could not see a particular constraint. Such constraints cannot be monitored by the DA/ID CCC process or other centralized processes. Those constraints could be, but not limited to, dynamic behavior of the internal Italian grid, unplanned outage that occurs after the deadline to update the inputs.

In particular, where relevant, Terna shall perform dynamic security assessment at least on a yearly basis in order to identify the maximum exchange level on the Internal Italian borders (for each border and, if relevant, in different scenarios) compatible with the stability of the Italian electrical system. The results of these assessments shall be also provided to the Italian NRA.

The TSO requesting a capacity reduction is required to provide a reason for this reduction, its location and the amount of MW to be reduced in accordance with article 26.5 of CACM regulation.

Where the two TSOs of a bidding zone border request a capacity reduction on their common border, the coordinated capacity calculator will select the minimum value provided by the TSOs. The reason associated to this value will be the one taken into account in all report required by relevant legislation.

For each border, direction and time unit, the final available capacity for the ID markets will be defined as the difference between the computed NTC value and the already scheduled/allocated flow in the previous market timeframes. If this difference is negative, no capacity will be made available to the market.

## 3.4. Backup & Fallback processes

### 3.4.1. Backups and replacement process

For all inputs related to the capacity calculation, standard backup communication process have been defined among GRIT TSOs and the coordinated capacity calculator. Where inputs are not available for one of the parties at the expected time, back up procedures are applied until a critical deadline is reached, in order to get the associated inputs and carry on with the original process.

Where a critical deadline is reached and the inputs could not be provided to the concerned party on time, then fallbacks are applied, meaning that GRIT TSOs and the coordinated capacity calculator could use other inputs to perform their tasks.

As an example, inputs from the day before, since network situations are usually stable from one day to another and could be re-used in order to complete the CCC process.

### 3.4.2. Fallback NTC values

If the GRIT TSOs and the coordinated capacity calculator could not complete a CCC process within the agreed time for calculation, the last coordinated cross border capacity calculated within the long term timeframe is then used as an input for validation.

The coordinated capacity calculator uses this Capacity as an input of the validation process. The TSOs have then the opportunity to adjust these values following the rules of this process.



## 4. Transparency

GRIT TSOs shall:

- fulfill the obligations from the Transparency regulation 543/2013;
- publish daily, NTC values computed in the DA CCC process;
- publish daily, NTC values computed in the ID CC process.

GRIT TSOs shall provide the relevant NRAs with a yearly report on the results of the DA CCC process:

- Cross-border capacities made available to the market during the previous solar year;
- Reliability margins applied (if any);
- Limiting CNECs.

GRIT TSOs shall provide the relevant NRAs with a yearly report on the results of the ID CCC process:

- Cross-border capacities made available to the market during the previous solar year;
- Reliability margins applied (if any);
- Limiting CNECs;

GRIT TSOs will participate in the elaboration of the ENTSO-E biennial report on capacity calculation and allocation, which will be provided each two years and updated under request of the relevant authorities, according to Article 31 of CACM GL. For GRIT region, this report will contain the capacity calculation approach used, statistical indicators on reliability margins, statistical indicators of cross-zonal capacity, quality indicators for the information used for the capacity calculation and, if appropriate, proposed measures to improve capacity calculation.

The Agency shall decide whether to publish all or part of this report.

## 5. Timescale for the CCM implementation

Article 9(9) of the CACM Regulation requires that:

*“The proposal for terms and conditions or methodologies shall include a proposed timescale for their implementation and a description of their expected impact on the objectives of this Regulation.”*

The deadline for implementing a harmonized CCM within a Capacity Calculation Region is defined in article 21(4):

*"All TSOs in each capacity calculation region shall, as far as possible, use harmonized capacity calculation inputs. By 31 December 2020, all regions shall use a harmonized capacity calculation methodology which shall in particular provide for a harmonized capacity calculation methodology for the flow-based and for the coordinated net transmission capacity approach."*

The following section provides the description of the planned implementation timeline for the GRIT capacity calculation methodology.

### 5.1. Prerequisites

When the new Capacity Calculation (CC) goes live, the calculation will be performed by the coordinated capacity calculator based on input provided by the TSOs, and finally validated by the TSOs. Two crucial elements in this process are the Common Grid Model (CGM) and the Industrialized Capacity Calculation Tool.

The CGM is being developed by a coordinated project of all EU TSOs, and the industrialized capacity calculation tool is being developed by the coordinated capacity calculator. Both shall be implemented before the "go-live" of the CCM.

### 5.2. Timeline for implementation of the CCM

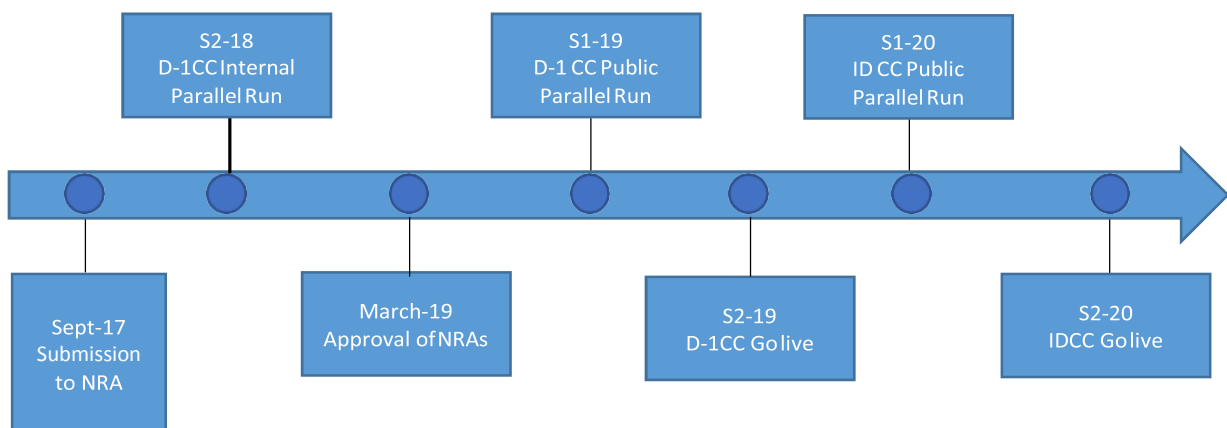

Figure 7: Timeline

Main dates:

- September 2017: Submission of the methodology for approval
- S2 2018: Start of Internal parallel run
- March 2019: Approval of the methodology by the GRIT NRAs
- S1 2019: Start of the Capacity Calculation for the day-ahead market timeframe External parallel run
- S2 2019: Go-Live criteria of the Capacity Calculation for the day-ahead market timeframe are met
- S1 2020: Start of Capacity Calculation for the intraday market timeframe parallel run
- S2 2020: Go-Live criteria of the Capacity Calculation for the intraday market timeframe are met